

Heal Force Laboratory Equipment

Heal Force specialises in the design, development, manufacture and sales of laboratory equipments in the fields of Biosafety protection, Centrifugation, Cell culture, Water purification & Gene amplification.



HFsafe CY Series

Ultrasafe triple filter biological safety cabinets

Biosafety Cabinet

Heal Force brand stands for safety, ergonomics and performance. Taking advantage of a heritage from over 25 years experience, Heal Force offers safety features, options and accessories beyond the standard requirements, to fulfill different needs. Thousands of units installed in laboratories in more than 100 Countries.

Centrifuge

Neofuge, the name that defines quality centrifuges from Heal Force. Offering bench-top high speed models with or without refrigeration for today's discerning laboratory technicians. Neofuge series provide excellent centrifugal effect and maximum application versatility.

CO₂/Tri-Gas Incubator

Heal Force Smart Cell incubator provides you with natural simulation to ensure optimum growth conditions for your culture at all time. That's why it is widely used in fields of application including tissue engineering, in vitro fertilization, neuroscience, cancer research and other mammalian cell researches.

Water Purification

Well-proved Heal Force water purification system offers ideal and comprehensive solution for a choice of water qualities that range from primary for simple routine washing and rinsing, through to ultra-high grade for different critical science and analytical applications.

Thermal Cycler

Since PCR is central for molecular biology research, you need flexible solutions that can help you achieve PCR success for virtually any application. Heal Force has been developing new cycling platforms from economical option to advanced series to empower your search. These instruments are renowned for their reliability, accuracy, and user-friendly interfaces.



Heal Force Bio-Meditech Holdings Group
 Heal Force International Trading(Shanghai) Co., Ltd
 6788 Songze Road, Qingpu District, Shanghai 201706, P.R. China
 Tel +86 21 62728646 Email export@healforce.com, Fax +86 21 62728646

www.healforce.com

Information is subject to change and/or updating without notice
 © 2020 Heal Force. For internal use only

The next level of performance

HFsafe CY
Biosafety Cabinet

Product and Solution Overview

Heal Force HFsafe CY biosafety cabinets specialise in quality, design, and innovation that comes from a heritage of over 25 years experience. At Heal Force we know how important it is to offer a high level of protection to operator, sample and environment with advanced technology. With an extensive track record of safety, reliability and performance, HFsafe CY cabinets make ideal investments for a wide range of applications including work with infectious agents that require biosafety level 1, 2 or 3 containment.

Table of Contents

Cytotoxic Safety Cabinet



What to look for in an ideal BSC **01**



Innovative triple filter technology **03**

04

Added level of safety and personnel protection



02

Global market vision



How to provide higher quality to meet different applications?

05

07

Advanced design for non-compromising safety

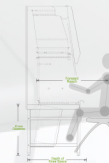

Enhanced effort and convenience

08

09

Decontamination and filter change



Easy to clean

10



Service access and validation

13

11

Options and Accessories



Engineering Drawing

15

14

Standard and test



16

General specifications



What to look for in an ideal BSC?



Global market vision

Proven Reliability

Outstanding safety is assured through a variety of core components and features to improve cleanliness and eliminate sample contamination risk.

Outstanding Comfort

With seven thoughtful features, from the view screen to the work environment and ergonomic design.

Added Conveniences

Packed with convenient features and large, unobstructed, usable work area in the industry, there's plenty of room for lab equipment and less hassle when managing controls.

Easy to Clean

An exceptionally reliable membrane-sealed control panel, and a multi-piece work surface featuring radiused, coved corners instead of seams, allows for easy and effective cleaning.

Energy Efficiency

From the motor controller to the lighting, new designs provide significant annual cost savings while maintaining superior performance.

Certified Performance

With front-access design, on-site validation, customer support packages, Main-tenance is quicker and easier.

TIMELINE



1999
Our first biological safety cabinet of clean-air product line



2005
One of the leading setters for YY0569 national standard formulation in China



2013
The only Chinese manufacturer invited to attend global seminar for BSCs



2014
HFsafe LC series are tested and certified to the North America standard NSF/ANSI 49

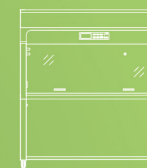

2016
We launch the DIN 12980 certified safety cabinet designed for preparing and handling cytotoxic drugs



NSF/ANSI 49

HFsafeLC series are independently tested and certified to NSF/ANSI 49, By NSF International, a testing agency in the USA.

EN12469

Our HFsafe LC series biological safety cabinets are independently tested and certified to EN12469 standard for Class II biosafety cabinets

DIN12980

Our HFsafe CY series cabinets with segmented worktops are registered and certified to the DIN12980 standard for safety cabinets for handling cytotoxic substances, requiring demanding personnel, product and environmental protection

YY0569

Heal Force, as a drafter for Chinese BSC standard, has her all series independently tested and certified to YY0569 standard for biological safety cabinet in China.



Advanced triple filter technology

Your biosafety concerns	Out solution : HFsafe CY series
Decontamination. Traditional Class II safety cabinets' air conducting channels, filters, fans are accumulatively contaminated, some of which like cytostatic substance can't be neutralized by formalin or hydrogen peroxide	Aerosols generated inside the work area are captured by the third stage filters preventing cytotoxic compounds to contaminate the interior of the cabinet
Filter lifespan. Conventional Class II B2 safety cabinets generate larger air volume for exhausting filters, causing shorter life span and higher running cost	1st V-Shaped HEPA filter is installed underneath the work plate to alleviate working burdens on supply and exhaust filters, extending the filter working life time.
Maintenance. The complicated filter change procedure does not protect personnel and environment from cytotoxic substance contamination.	Replacement of the HEPA filters thanks to the patented system is obtained without any risk of exposure to dangerous compounds both for the workers and the environment.
External Ducting. An extra active carbon post filter is recommended if Class II A2 & B2 BSCs are used for hazardous operation. Dedicated extract duct generates high installation costs	Aerosols generated inside the work area are retained by HEPA filter, so the filtration efficiency >99.99999997 % of 3 µm- better than ULPA filters. External ducting is not necessary.
Installation limits. The installation process requires detailed guidance due to the large exhaust air volume for Class II B2 BSC. Leading to limited numbers of units in one room	70% recirculation and 30% exhaust airflow pattern inside the cabinet reduces the indoor air exchange rate. There are less quantity limits for installation
Energy consumption. The standard exhaust system for Class II B2 BSC will extract indoor air out, keeping the air conditioner working and causing high energy consumption. The overall running cost is high	Features like self-induced EBM PAPST blower, large area V shaped HEPA filter, Low-vel ECO mode all contribute to low energy consumption, consequently lower air conditioning demands
Cleanliness. The supply filter provides ISO class 5 or class 3 laminar flow clean air to the work surface if HEPA/ULPA filter is utilized.	Three levels filtration of the recirculated air exceeds the required air cleanliness for the preparation of parenteral drugs and also the safety of the environment

Added level of safety and personnel protection

HFsafe CY cabinets work in the same way as conventional Class II cabinets, however there is additional HEPA filtration below the work surface. This filtration enables a filter change without exposing the ambient environment or service personnel to potential hazards.

Protect the operator and environment

Operator protection is obtained thanks to the excellent containment efficiency of the front air barrier formed by a combination of inflow and down flow air streams and filtration of the air discharged in the environment.

Protect the product and the patient

The sterility of the drugs is essential for the safety of the patient. The air passes through the downflow ULPA filter and into the work area as a vertical laminar flow air stream bathing the work surface in clean air. The uniform, non-turbulent air stream protects against cross-contamination within and throughout the work area.

Protect the engineers

With the HEPA H14 filters placed underneath the work surface and the inflow air having a very short pathway, aerosols generated inside the work area are retained, preventing all other air conducting channels, filters, fans etc. from any contagion. This design provides easy and safe 1st HEPA filter changes under safe negative pressure.



How to provide higher quality to meet different applications?



Self-induced Blower

German made ebm-papst motors selected for energy efficiency, compact design, and flat profile. Synchronously communicates with microprocessor, there is no need for manual speed control. Automatically compensates for normal power line variation, air disruption and filter loading. Motor consumes less energy, reduces heat output and operates more quietly.



ULPA Filtration System

HFsafe CY biosafety cabinets are equipped with long life ULPA filtration technology by AAF. Supply and exhaust filters provide 99.999% typical efficiency for particle size of 0.1 to 0.2 microns, providing superior product protection over conventional HEPA filters. Silicate glass fiber treated with moisture-proof hydrophobic bonding agent is folded in aluminum alloy frame to enlarge filtration area. Leak-free performance is guaranteed through structural stability and scan test conducted prior to shipping. Self-compensation for the clogging of filters optimizes filter use and minimizes service.

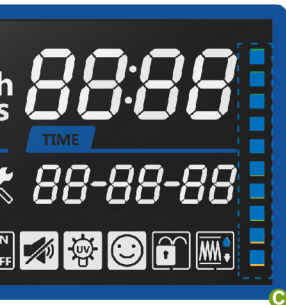

Filter Life Indication

Filters has estimated service life, which is uncertain subject to different local air quality, research subjects and operation frequency. There is potential pollution hazard if operator is unconscious to filter expiration. Life indicator for supply/exhaust/1st HEPA filter is designed to measure filter life according to actual condition of membrane. You can rely on filter life indicator to make a confident plan for future filter replacement.

Sixfold Airflow Monitoring

Two temperature-compensated airflow sensors and two pressure sensors ensure safe operating conditions are maintained. Downflow/exhaust anemometers are standard configuration, incorporating two airflow probes respectively, quadrupling flow speed accuracy and security. The pressure sensors on the downstream side of 1st HEPA filter and upstream side of main ULPA filter surveils monitor the working condition of the filtration system. Six independent sensors provides instant and precise feedback to the blower so that its speed remains constant regardless of changes in conditions, such as filter loading. Alarm thresholds ($\pm 10\%$ of the control panel) are precisely controlled via microprocessor which guarantees excellent airflow performance.

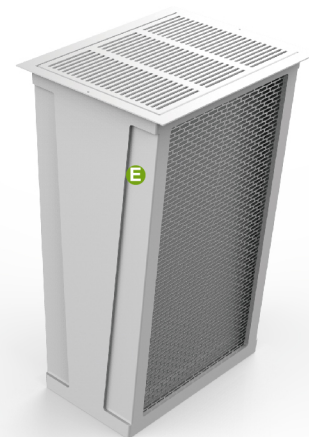

Friendly Communication

The durable LCD is mounted at eye level for at-a-glance viewing of airflow, operating parameters, and alarm messages. The intuitive interface delivers a constant read-out of working area temperature, air velocity/volume, filter life span, total running time. Easy-to-clean touchpad controls allow manual activation of blower, lamp, UV, electrical receptacles and menu selection. Engage the security lock feature to prevent access to the cabinet by unauthorized or unfamiliar users.

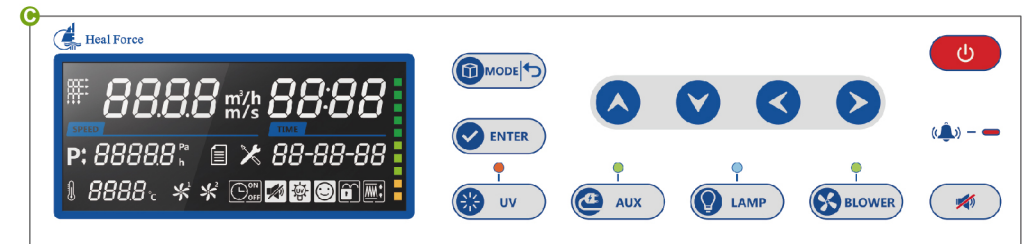

Robust Construction & Compact Design

Energy saving epoxy/polyester coated steel exterior with solid construction, nice looking curves and fresh colour. Constructed of seamless, non-porous, autoclavable Type 304 stainless steel for working plate, one-piece side/rear walls and bottom sink.

Slim, compact design and dimensions allows for easy positioning and location in the laboratory, can be easily transported through standard 800 mm doorways.

The low cabinet height allows the choice of bench top location or mounting on a support stand, easily accommodated in a laboratory with 2.5m ceiling height.

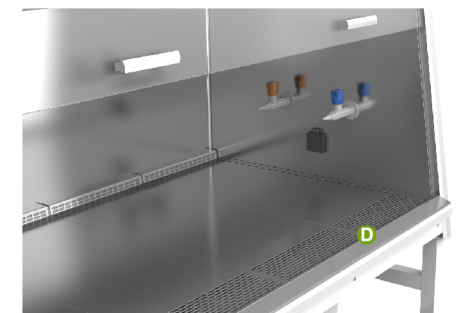

1st V-Shaped HEPA filter

An additional segmented H14 HEPA filter is used underneath the work surface, Inner air ducts, plenums and fans are protected from contamination. The cumulative filtration efficiency is 99.99999995% to the downflow and exhaust airflow. Incorporating separated HEPA filters, which enlarge filtration area and give a longer working life. Easy and safe HEPA filter changes in the work area under safe negative pressure.

Non-compromising safety

Behind every great discovery, there is the technology that made it all possible.

Behind the primary function to provide you cleanliness and containment, there's the technology that made it all possible. Heal Force Flow-saFe, Lab-AleRt, Low-Vel are innovations designed to increase safety and minimize sample contamination



Flow-saFe technology is designed to ensure your safety. Laminar airflow over the working area takes containment to new levels

Smart and self-induced motor monitors and controls fan speed in real time to maintain constant airflow during filter loading or temporary obstruction.

Flow-safe system automatically balances the downflow and inflow velocities to maintain user and sample protection

Uniform, non-turbulent air stream protects against cross-contamination within the work area



Complete your operation requirements with Heal Force Lab-AleRt monitoring solution.

Lab-AleRt makes the monitoring of your biosafety cabinet easier. You can keep a constant check on the airflow, window position etc.

Monitoring system alerts user when containment is compromised

Independent sensors detect airflow changes constantly to ensure safe operating conditions.

Airflow velocities are displayed on the control panel for monitoring and recording.

Visual and acoustic alarm for indication of unsafe airflow conditions and window position

A sash position indicator decal provides a visual confirmation of the proper working height



Save energy, maintains sterility

When the front sash is closed, our intelligent speed control automatically reduces flow speed

Less air flows through the ULPA filters, extending filter life and decreasing energy consumption.

Continuous airflow helps to maintain a sterile working environment, even when the cabinet is not in use



Hy-ChamBer plenum design with long life and lasting containment surrounds contaminated areas

Negative-pressure, dual side walls prevent the possibility of contamination from leaks to the exterior environment

Enhanced comfort and convenience



Sloped front design for higher operational comfort and larger work area visibility



Counterbalanced sliding sash can be raised to a maximum height for easy introduction of large items



Ergonomic lighting is positioned outside the work area. This does not disturb the downflow, nor create inconvenient shades, nor create obstructions during cleaning.

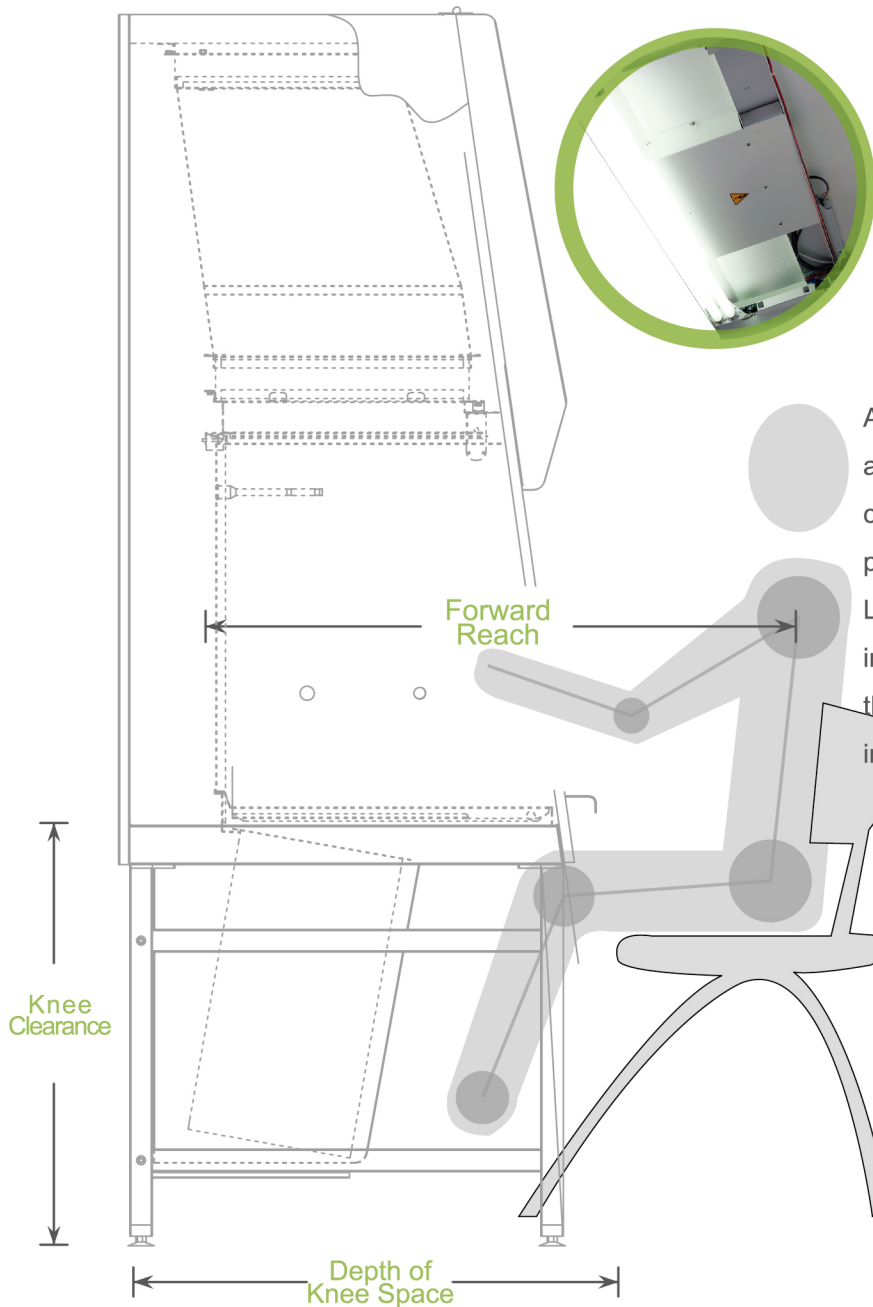

Arm rest operates like an aerofoil, contributing to the comfortable working position of the operator. Located just above the intake grill, it also ensures that the air vents are not inadvertently obstructed.

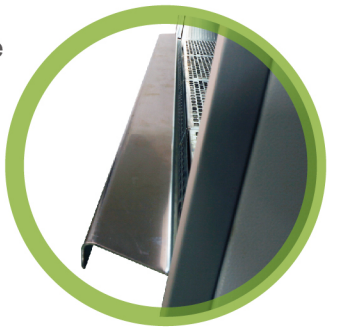

Complete operator comfort without leg restriction when seated

Decontamination

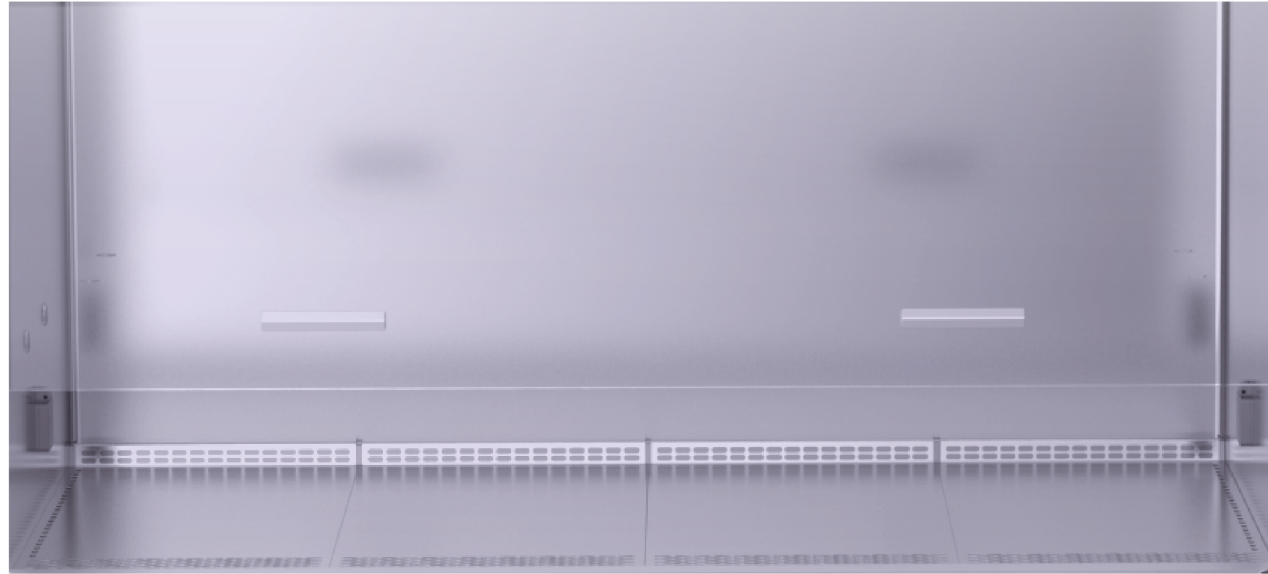

Programmable automatic UV light timer simplifies operation while extending UV lamp life and saving energy.
Powerful UV irradiation illuminates entire work area, design to ensure thorough disinfection of the complete chamber
UV lamp with interlocking safety switch allowing operation only when blower and fluorescent light are off and sash is fully closed
The hidden UV lamp protects operator' s eyes from hurt

V-shaped filter changing

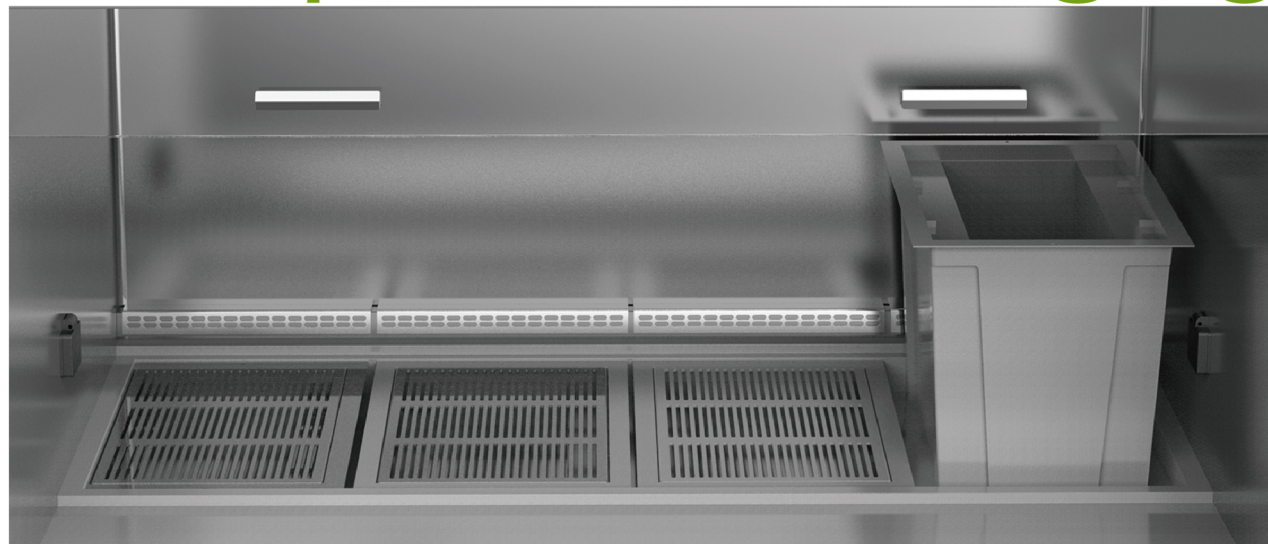

The cabinet design allows for safe filter change and disposal from within the chamber whilst the cabinet is operating, thus protecting the operator during this procedure.

Easy to Clean



The standard stainless steel work tops of cabinets are constructed in 30 cm sections for easy removal and cleaning on all surfaces which can easily be autoclaved if required.

The cabinet work zone has no welded joints to collect contaminants or rust. Detailed of cabinet developed further to ensure easier cleaning with normal cleaning solvents.



The water pathway is designed, making liquid flow to the sink, for better HEPA filter protection and easy clean work.
The drip tray underneath the worktop collects spilled liquids more than 4 Litres, preventing these liquids from entering parts of the cabinet that are difficult to clean.

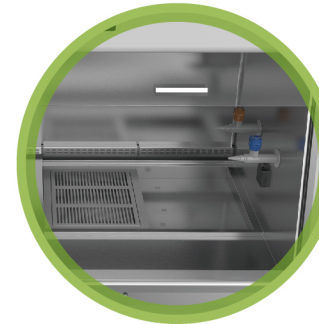

Eye level control panel with soft touch control key is seamlessly incorporated, for water-proof and routine clean.



Airflow laminator protects the filter surface during wipe cleaning.



Options and Accessories

Support stand

Saves lab bench space and ensure stability & ergonomic working position
 Standard heights available: 560mm (22.0") , 660mm (34.0") or 760mm (29.9")
 Manual adjustable leveling feet to compensate for ground unevenness.
 Available with castors (option) for easy re-location or transportation.
 Durable polyurethane caster wheels with 360 degree horizontal rotation

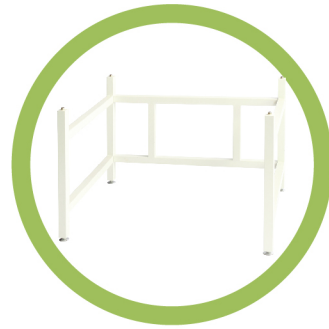

Ultraviolet Lamp Kits

Controlled by automatic UV lamp timer through microprocessor control panel
 Emission of 253.7 nanometers for efficient decontamination
 Lamp is positioned away from operator line of sight for safety and proper exposure to interior surfaces
 Optional mobile UV lamps strengthen the decontamination effect



Illumination Light

Illumination light provides sufficient brightness to the working chamber. There are two illumination lamps located at inner side of the front panel.



Worktop

The polished, standard stainless steel Multi-piece table top is easy to remove for cleaning
 This flexibility of work top choice enables the HFsafe CY to be configured to suit your exact practical requirements.
 Other options are available to suit customer requirements

Active Carbon

Disposable, impregnated carbon filters (AAF) trap non-volatile nuisance odors of chemicals
 Compared with tradition top mounted or tunnel mounted type, this structure enlarges the adsorption area and eliminate retain odors before supply and exhaust filtration.
 Interchangeable and modular V shape design facilitates the change between HEPA and active carbon filter.



Others

Two electrical duplex receptacles, with ground fault interruption and splash covers.
 Service valves for Gas, Water and Vacuum mounted on side wall.
 PVC Armrest Chemically treated, improves operator comfort, easy to clean
 Foot pedal for front window control
 Loop heat sterilizer



Exhaust connection fitting

If biosafety cabinets are used for minute quantities of volatile toxic chemicals and trace amounts of radionucleotides required as an adjunct to microbiological research, they must be exhausted through properly functioning exhaust canopies.
 The extraction of exhaust air from HFsafe LC cabinet is usually achieved by either a dedicated or "shared" extract duct, in either case it is always via an electric closed exhaust valve & constant flow rate valve with a coordinated control system.

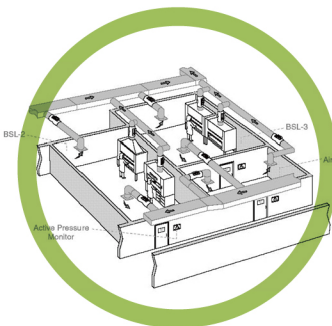

Contact Heal Force for ordering information and technical assistance in selecting the right ductwork for your installation.



Service Access & Validation

All services, adjustments and filter change is carried out from the front of the cabinet.

Service Access

Help for certifiers, the maintenance assembly opens to a fixed position, providing front service access. Consequently, the cabinet can remain in-suit without making any positional changes in your laboratory or having to disconnect any ducting.

All service is performed from the front of the cabinet, including:

- Change of filters
- Fluorescent lamps
- UV lamps
- Adjustment or change of circuit boards and sensors
- All adjustments to alarms, fan speeds, are made via the microprocessor control panel
- Service code protected

Validation

Heal Force offers a wide range of high quality services for all our equipment. These services include on-site validation, customer support packages, factory acceptance testing.

Choose Heal Force as an equipment supplier and validation consultant can greatly reduce the time and cost involved with getting new equipment compliant and ready for use.

Services Heal Force Offers:

On-site consultation

- Unit specific authorized protocol documents
- Customizable testing procedures to meet customer specific requirements
- Unbiased testing of competitive equipment

Pre-delivery Services:

- Validation support
- Consultation
- Factory acceptance testing

On-site Services:

- Installation qualification
- Operational qualification
- Calibration



Standards & Test

Standards Compliance

Biosafety Cabinets	DIN12980:2005, EN12469:2000, Germany / SFDA YY0569:2000, China
Air Quality	Superior to ISO 14644.1, Class 3, Worldwide
Filtration	EN-1822, Europe/ IEST-RP-CC001.3, Worldwide/ IEST-RP-007, Worldwide/ IEST-RP-CC034.1, Worldwide
Electrical Safety	EN61010-1, Europe/ IEC61010-1, Europe
Manufacturer Qualification	ISO 13485:2003, ISO 9001:2008

Comprehensive performance testing

Every HFsafe CY model manufactured by Heal Force is individually tested, documented by serial number and validated with the following test methods.

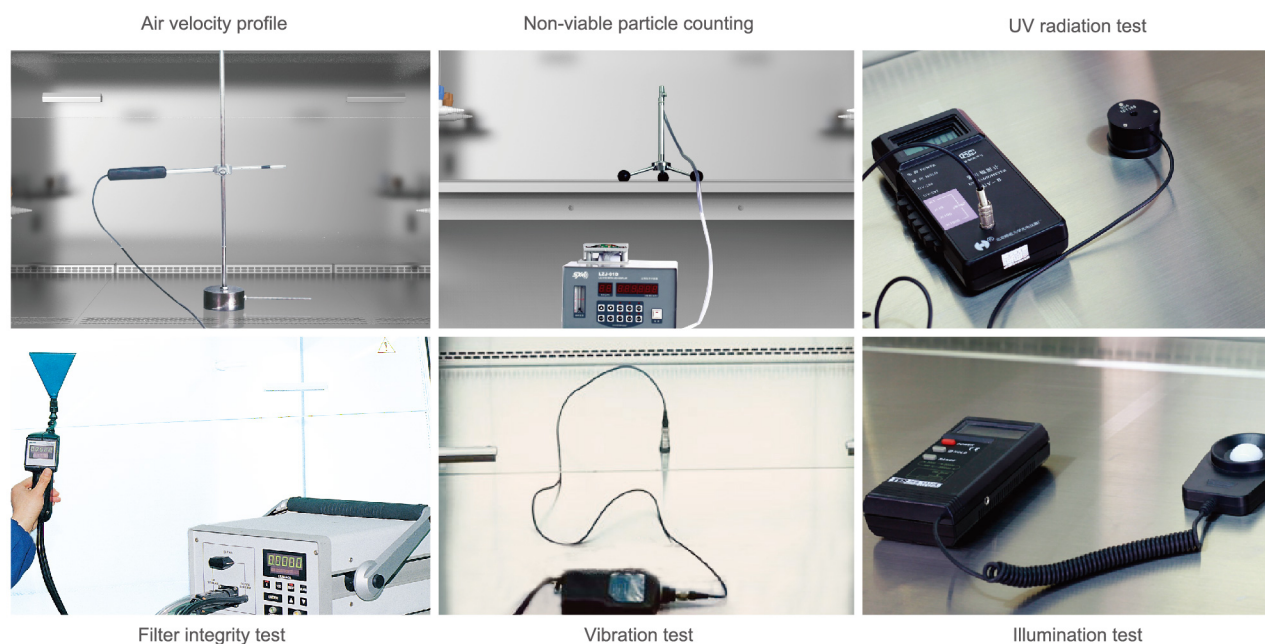

KI Discus Containment Test According to EN12469 (Potassium Iodide)

Heal Force is currently one of the companies in the world equipped to perform the KI Discus test for validating the operator/personnel protection capabilities of biosafety cabinet.

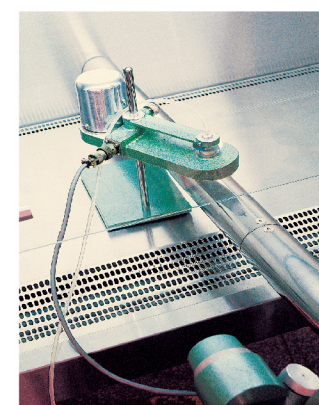

KI-discus containment test 1

The KI Discus test shows excellent correlation with the microbiological test method for operator protection, and is useful for validating the actual containment performance of the cabinet on-site.

The KI-Discus takes only 45 minutes as opposed to 2 days for microbiological testing. Thus, Each HFsafe model is factory tested on a sampling basis using the KI-Discus method for operator safety.



KI-discus containment test 2

HFsafe CY Cytotoxic Biological Safety Cabinet Technical Specification

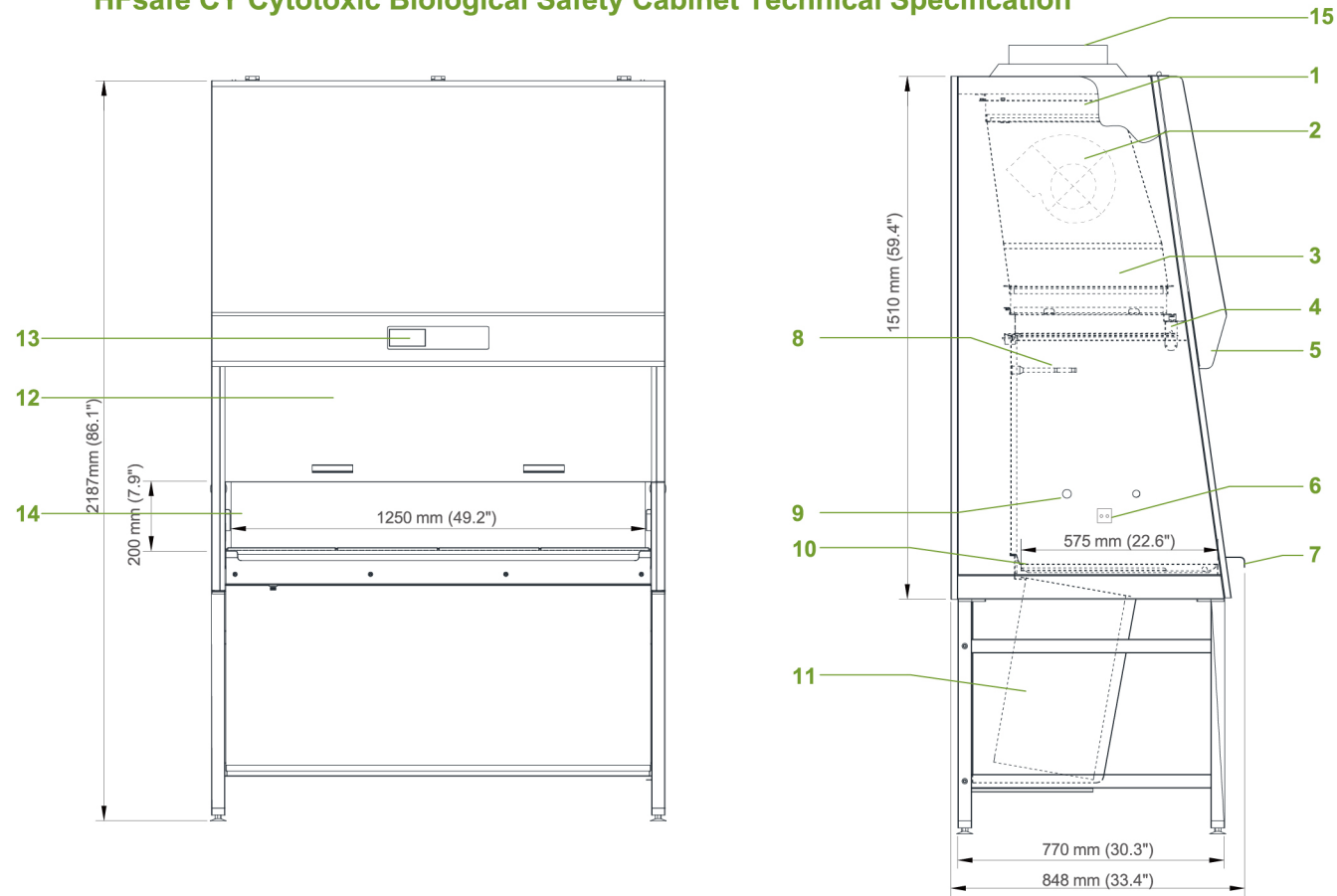

- | | | |
|---|------------------------------------|---|
| 1.Exhaust filter | 7.Stainless steel armrest | 13.Micro processor control system |
| 2.Blower | 8.Downflow sensor | 14.Single piece stainless steel back well and side wall |
| 3.Downflow filter | 9.Gas/vacuum/water service fixture | 15.Thimble exhaust collar (optional) |
| 4.Standard UV light | 10.Stainless steel work tray | |
| 5.Fluorescent light | 11.1st V shaped HEPA filter | |
| 6.Universal electrical outlet (2 single outlets in work zone) | 12.Manual sliding window | |

Optional Exhaust Collar Positions for Thimble-Ducting for HFsafe CY Models

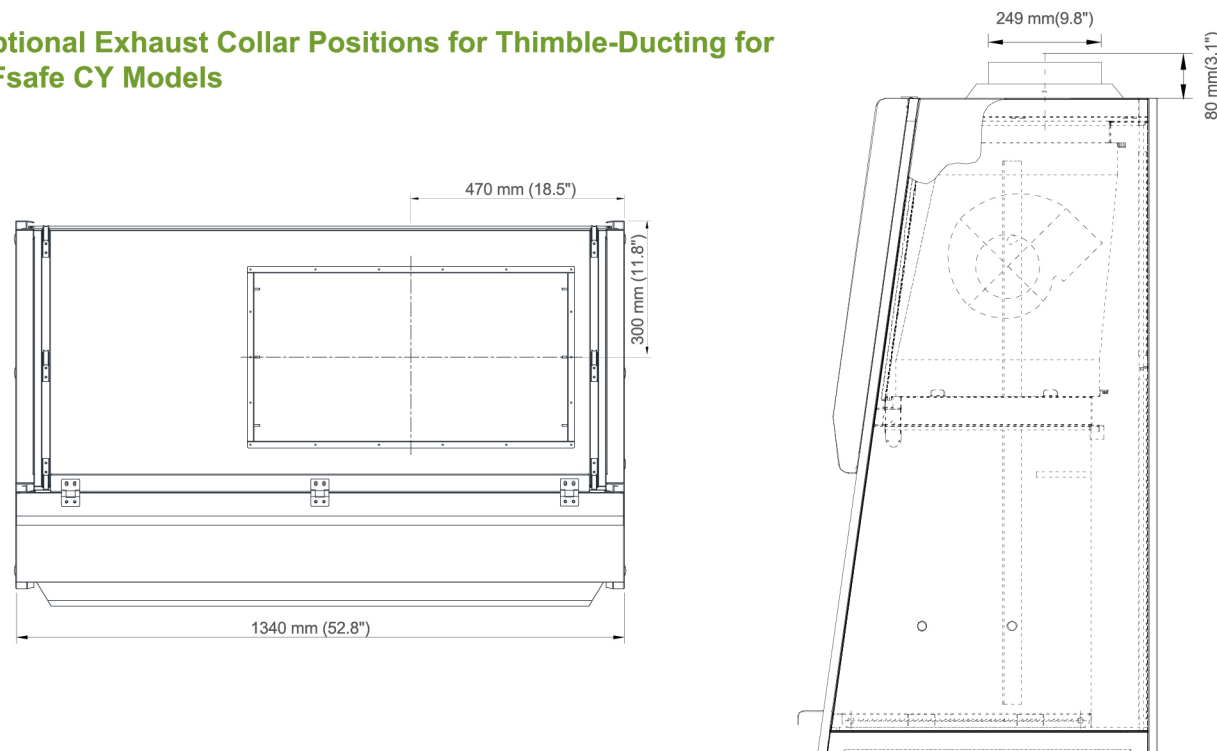

General Specifications, HFsafe CY Cytotoxic Biological Safety Cabinets

Model	Hfsafe-1200CY	Hfsafe-1500CY
Nominal Size	1.2 meters(4')	
External Dimensions with Base Stand (W×D×H)	1340×850×2190mm (52.8"×33.5"× 86.2")	1640×850×2190mm (64.6"×33.5"× 86.2")
Internal Work Area, Dimensions (W×D×H)	1250×650×600mm (49.2"× 25.6"× 23.6")	1550×650×600mm (61.0"× 25.6"× 23.6")
Internal Work Area, Space	0.79m ² (8.5sq.ft)	0.79m ² (8.5sq.ft)
Average Airflow Velocity *		
Inflow	0.53m/s (104.3fpm)	0.53m/s (104.3fpm)
Downflow	0.32m/s (62.99 fpm)	0.32m/s (62.99 fpm)
Airflow Volume		
Inflow	477m ³ /h(280cfm)	592m ³ /h (348cfm)
Downflow	864m ³ /h(508cfm)	1071m ³ /h (630cfm)
Exhaust	477m ³ /h(280cfm)	
ULPA Filter Efficiency		
Downflow	≥99.9995%@MPPS(ULPA)	≥99.9995%@MPPS(ULPA)
Exhaust	≥99.9995%@MPPS(ULPA)	≥99.9995%@MPPS(ULPA)
HEPA Filter Efficiency		
1st V shaped filter	≥99.9995%@MPPS(HEPA)	≥99.9995%@MPPS(HEPA)
1st V shaped HEPA filter no.	4	
Biosafety Protection Test	KI-Discus containment and microbiological testing is performed	
Personnel Protection Test	KI-Discus containment and microbiological testing is performed	
Product Protection Test 1~8×106 (three times in succession)	≤5CFU	≤5CFU
Cross-contamination Test 1~8×106 (three times in succession)	≤2CFU	≤2CFU
Sound Emission	≤60dBA (DIN 12980)	≤60dBA (DIN 12980)
Fluorescent Light Intensity	≥800Lux	≥800Lux
Excellent light distribution	Yes	
RMS	≤5um	
Cabinet Construction	1.2mm(0.05") steel with white oven-baked epoxy-polyester	
Main Body	1.2mm(0.05") steel with white oven-baked epoxy-polyester	
Work Zone	stainless steel, type 304	stainless steel, type 304
Side Walls	stainless steel, type 304	stainless steel, type 304
Window material	Hardened/laminated safety glass	
Front aperture opening height	200mm	
Backward-slanted safety glass angle	8°	
Electrical		
Cabinet Full Load Amp(FLA)	2A	
Fuses (A)	10	
Power Supply	1800VA	1800VA
Optional Outlets FLA	5A	
Total Cabinet FLA	7A	
Power Supply**		
220V/50Hz	Yes	Yes
220V/60Hz	Yes	
110V/60Hz	Yes	
Net Weight	331kg(730lbs)	390kg(858lbs)
Shipping Weight	468kg(1032lbs)	
Shipping Dimensions Maximum(W×D×H)	Box1. 1426×946×1710mm (56.1"×37.2"×67.3")	
	Box2. 1496×716×963mm (58.9"×28.2"×37.9")	
Shipping Volume, Maximum	Box1. 2.31m ³ (81.5cu.ft.) Box2. 1.03m ³ (36.4cu.ft.)	

* at initial setpoint with uniformity of better than +/-20% ** Please contact us for more optional power supply information